

APPLICABLE STOCK NO.
5680-9003-9

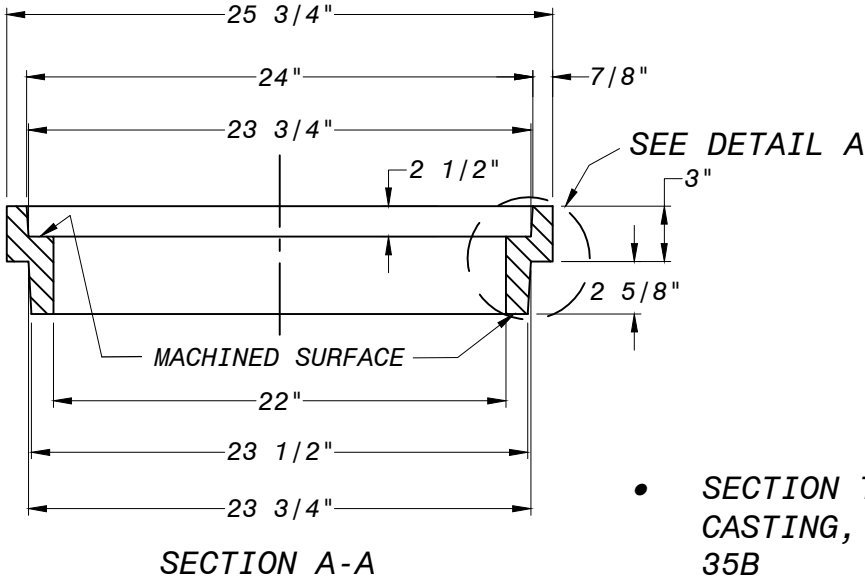
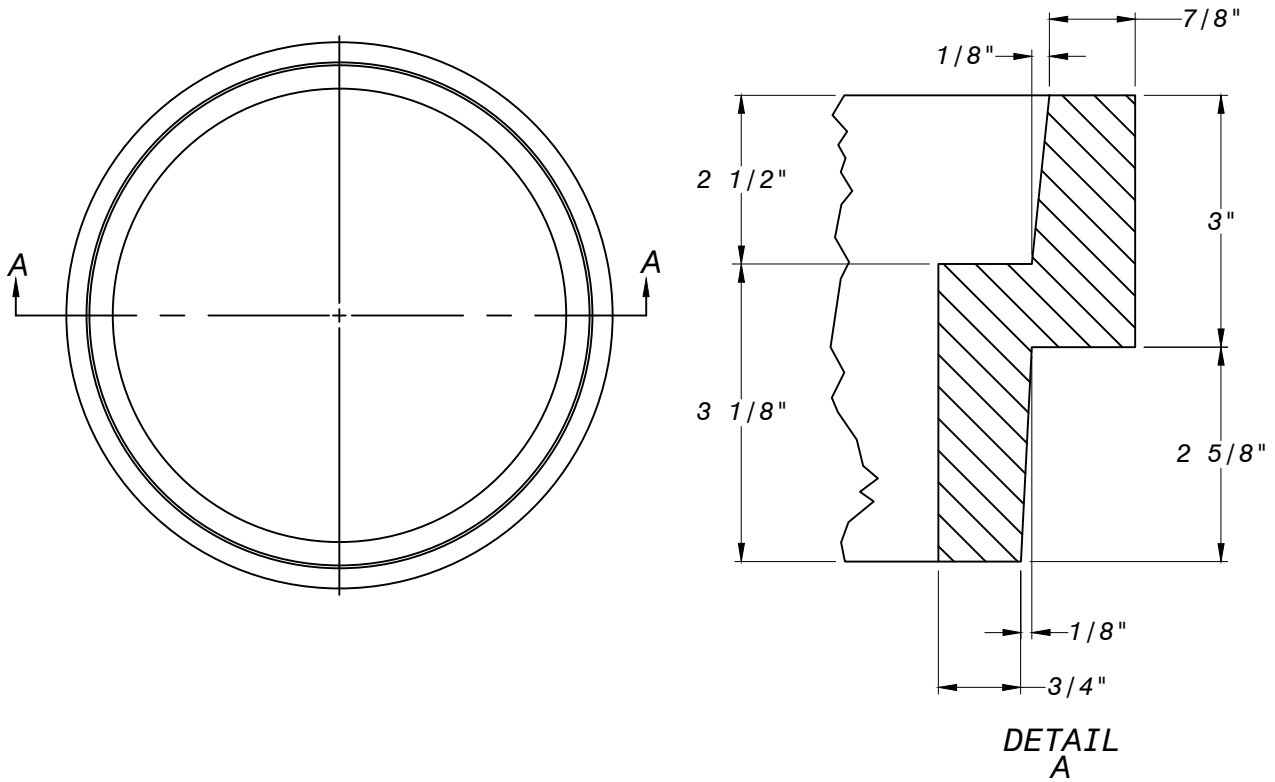

- SECTION TO BE GRAY IRON CASTING, ASTM A-48 CLASS NO. 35B
- CASTING SHALL CONFORM TO AND BE MANUFACTURED IN ACCORDANCE WITH THE REQUIREMENTS OF AASHTO STD M306, LATEST REVISION

ALL DIMENSION ARE IN INCHES
UNLESS OTHERWISE SPECIFIED.

TOLERANCES: $\pm 1/16$ "

WASHINGTON
SUBURBAN
SANITARY
COMMISSION

REVISIONS:
APPROVED: May 4, 2021 | 12:46 PM EDT

DocuSigned by:
Jaime Garcia

B7DBE23469C84BD
MATERIALS MANAGEMENT DIVISION MANAGER

PROCUREMENT AND MANUFACTURING DETAIL
**22-INCH NON-WATERTIGHT
MANHOLE ADJUSTING RING,
3" HEIGHT**

**P&M
6.1**